

Service Manual

Separate Mini Component System
MD Deck

MDG-X5 (UK)

MDG-077 (XE)

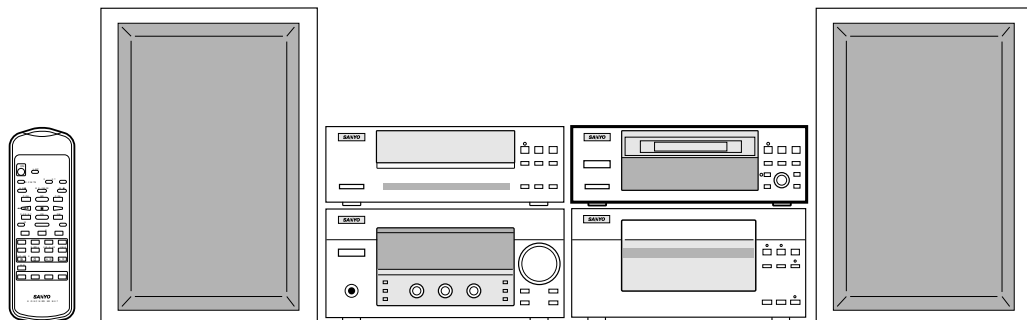

Specifications

Sampling frequency 44.1 kHz
Laser output 7.04mW(Continuos wave max.)
Wave length 785nm
Wow/flutter Below measurable limits
Recording system Magnetic modulation over write
Input/Output OPTICAL DIGITAL IN/OUT : Optical
Power supply Supplied from the Tuner/Amplifier
Dimensions 270 (W) x 87 (H) x 285 (D) mm
Weight 2.3 kg

Specifications subject to change without notice.

PRODUCT CODE No.

137 088 08 (UK)

137 088 09 (XE)

LASER BAEM SAFETY PRECAUTION

- Pick-up that emits a laser beam is used in this CD player section.

CAUTION :

USE OF CONTROLS OR ADJUSTMENTS OR PERFORMANCE OF PROCEDURES OTHER THAN THOSE SPECIFIED HEREIN MAY RESULT IN HAZARDOUS RADIATION EXPOSURE

LASER OUTPUT.....0.6 mW Max. (CW)

WAVE LENGTH 790 nm

(MD DECK)

CAUTION - NVISIBLE LASER RADIATION WHEN OPEN AND INTERLOCKS DEFEATED. AVOID EXPOSURE TO BEAM.

ADVARSEL - USYNLIG LASER STRÅLING VED ÅBNING, NÅR SIKKERHEDSAFBRYDERE ER UDE AF FUNKTION, UNDGÅ UDSÆTTELSE FOR STRÅLING.

VARNING - OSYNLIG LASER STRÅLNING NÅR DENNA DEL ÄR ÖPPNAD OCH SPÄRR ÄR URKOPPLAD. STRÅLEN ÄR FARLIG.

VORSICHT - UNSICHTBARE LASERSTRAHLUNG TRIT AUS, WENN DECKEL GEÖFFNET UND WENN SICHERHEITSVERRÄGELUNG ÜBERBRÜCKT IST. NICHT, DEM STRAHL AUSSETZEN.

VARO - AVATTAESSA JA SUOJALUKITUS OHITETTAESSA OLET ALTTIINA NÄKYMÄTTÖMÄLLE LASERSÄTELYLLE. ÄLÄ KATSO SÄTEESEEN.

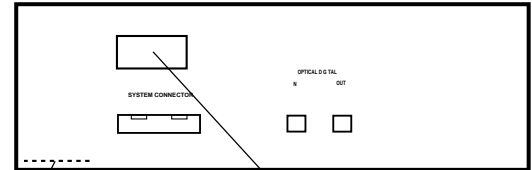

CLASS 1 LASER PRODUCT
LUOKAN 1 LASERLAITE
KLASS 1 LASERAPPARAT

(XE)

REPLACEMENT AND LUBRICATION OF THE MD DOOR

Remove it from, and is a method MD door

1. A point of a coil(Front right side) is pinched with tweezers, and it is taken off a hole of MD door.
A spring turns then, and seem not to be exhausted.
2. A ditch of a door is to be pushed from face, and MD door is taken off an axis.
3. MD door axis is avoided.

MD door installation method

1. Put molykote (EM-30LG) on door contact department.
2. Fit turns an axis into ditch 2 places of MD door after installing door shaft, and install it with care in installation direction.
3. Pinch a point of coil spring with tweezers, and hang it on a hole of a door.

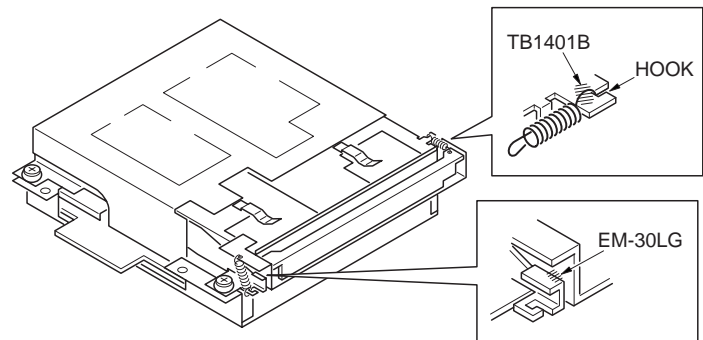

EXPLODED VIEW (CABINET, CHASSIS & MD MECHANISM)

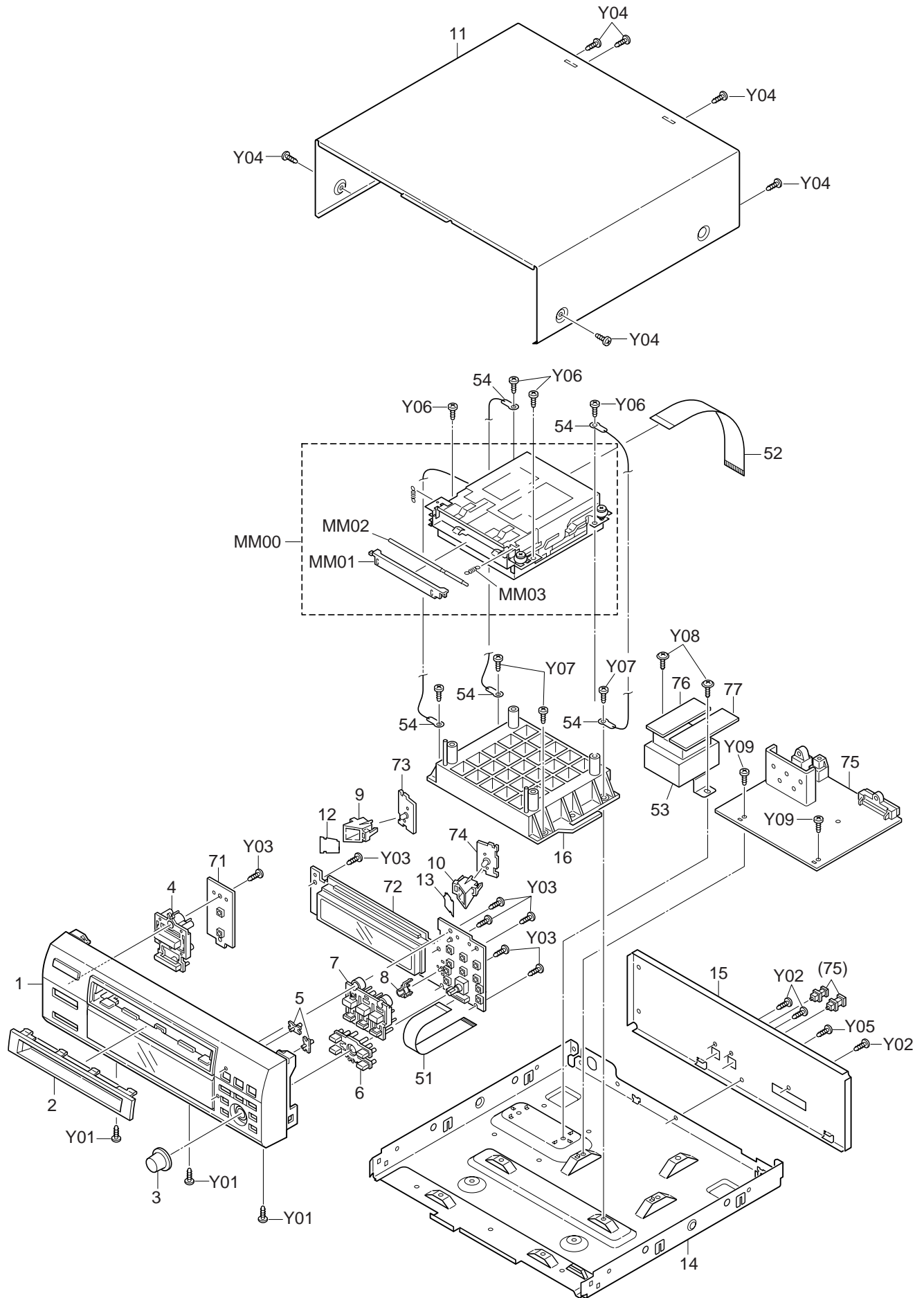

PARTS LIST

PRODUCT SAFETY NOTICE

EACH PRECAUTION IN THIS MANUAL SHOULD BE FOLLOWED DURING SERVICING. COMPONENTS IDENTIFIED WITH THE IEC SYMBOL Δ IN THE PARTS LIST AND THE SCHEMATIC DIAGRAM DESIGNATED COMPONENTS IN WHICH SAFETY CAN BE OF SPECIAL SIGNIFICANCE. WHEN REPLACING A COMPONENT IDENTIFIED BY Δ , USE ONLY THE REPLACEMENT PARTS DESIGNATED, OR PARTS WITH THE SAME RATINGS OF RESISTANCE, WATTAGE OR VOLTAGE THAT ARE DESIGNATED IN THE PARTS LIST IN THIS MANUAL. LEAKAGE-CURRENT OR RESISTANCE MEASUREMENTS MUST BE MADE TO DETERMINE THAT EXPOSED PARTS ARE ACCEPTABLY INSULATED FROM THE SUPPLY CIRCUIT BEFORE RETURNING THE PRODUCT TO THE CUSTOMER.

CAUTION : Regular type resistors and capacitors are not listed. To know those values, refer to the schematic diagram.
 Regular type resistors are less than 1/4 W carbon type and 0 ohm chip resistors.
 Regular type capacitors are less than 50 V and less than 1000 μ F type of Ceramic type and Electrical type.

PACKING & ACCESSORIES

REF.NO.	PART NO.	DESCRIPTION
	614 305 2135	CARTON CASE,INNER (DC-X5/UK)
	614 305 2142	CARTON CASE,INNER (DC-077/XE)
	614 302 0752	CUSHION,FRONT,FRONT
	614 302 0769	CUSHION,BACK,BACK
	645 036 4334	POLY SHEET-0750X0400*NC, SET (DC-X5/UK)
	645 036 4341	POLY SHEET-0750X0400*NC, SET (DC-077/XE)
	645 036 9643	CABLE,OPTICAL
	614 302 5306	INSTRUCTION MANUAL (UK)
	614 303 9822	INSTRUCTION MANUAL (XE)
	614 307 0603	INSTRUCTION MANUAL,GREEK (XE)

CABINET & CHASSIS

REF.NO.	PART NO.	DESCRIPTION
1	614 302 8468	ASSY,CABINET,FRONT
2	614 305 1114	ASSY,DEC MD
3	614 302 4361	KNOB,ROTARY,JOG
4	614 302 4248	BUTTON,EJECT,OPEN/CLOSE
5	614 302 0530	DEC,WINDOW LED,PLAY COMPU REC
6	614 302 4255	BUTTON,EDIT
7	614 303 7330	BUTTON,PLAY,PLAY/PAUSE
8	614 302 4354	HOLDER,LED,COMPU REC
9	614 302 9687	REFLECTOR,LED,LEFT
10	614 302 4415	REFLECTOR,LED,RIGHT
11	614 304 7834	ASSY,CABINET,AFTER BENDING
12	614 303 6432	DEC,SHEET,LED,LEFT
13	614 302 4330	DEC,SHEET,LED,RIGHT
14	614 302 8956	ASSY,CABINET,BOTTOM
15	614 302 4385	PANEL,REAR,REAR (UK)
15	614 304 0057	PANEL,REAR,REAR (XE)
16	614 302 4378	MOUNTING,MD,MECHA
	614 274 8190	LABEL,SAFETY,LASER

FIXING PARTS

REF.NO.	PART NO.	DESCRIPTION
Y01	411 021 3503	SCR S-TPG BIN 3X10, FRONT-BOTTOM FIX
Y02	411 021 3701	SCR S-TPG BIN 3X10, REAR-ELECT PART
Y03	411 021 3503	SCR S-TPG BIN 3X10,FRONT PWB FIX
Y04	411 021 3701	SCR S-TPG BIN 3X10,CABINET
Y05	411 021 3701	SCR S-TPG BIN 3X10,BOTTOM-REAR
Y06	411 023 4003	SCR S-TPG PAN 3X10,MD MECHA
Y07	411 021 3503	SCR S-TPG BIN 3X10, MOUNTING-BOTTOM
Y08	411 020 9902	SCR S-TPG BRZ+FLG 3X8,TRANS
Y09	411 021 3503	SCR S-TPG BIN 3X10,MAIN PWB

ELECTRICAL PARTS

REF.NO.	PART NO.	DESCRIPTION
51	645 036 9650	FLEXIBLE FLAT CABLE, MECHA-FRONT PWB
52	645 037 3190	FLEXIBLE FLAT CABLE, MECHA-POWER SUPPLY PWB
53	Δ 645 034 8020	TRANS,POWER
54	614 129 9082	LUG

MD SWITCH P.W.BOARD ASSY

REF.NO.	PART NO.	DESCRIPTION
71	614 303 3851	ASSY,PWB,MD SW(Only Initial)
CN543	614 035 4911	SOCKET,DIP 2P
or	614 237 9752	SOCKET
S5430	645 006 5958	SWITCH,PUSH 1P-1T
or	614 220 5471	SWITCH,TACT
or	614 240 1002	SWITCH,TACT
S5431	645 006 5958	SWITCH,PUSH 1P-1T
or	614 220 5471	SWITCH,TACT
or	614 240 1002	SWITCH,TACT

MD FRONT P.W.BOARD ASSY

REF.NO.	PART NO.	DESCRIPTION
72	614 302 6792	ASSY,PWB,MD FRONT (Only Initial)
CN530	614 303 1550	ASSY,WIRE
CN531	614 302 4231	ASSY,WIRE
CN532	645 034 8631	SOCKET,FPC 23P
CN533	614 035 4911	SOCKET,DIP 2P
or	614 237 9752	SOCKET
CN534	614 035 4911	SOCKET,DIP 2P
or	614 237 9752	SOCKET
CN535	614 035 4911	SOCKET,DIP 2P
or	614 237 9752	SOCKET
D5301	408 037 4204	LED SLP-3118B-51HAB-T1
D5302	408 032 5404	LED SLP-9118C-51H-S-T1
FL501	645 034 8044	FLOURESCENT TUBE
HL530	614 302 4347	HOLDER,FL,HOLDER-FL
IC531	410 342 8303	IC M38197MAA-625FP
IC532	409 427 7805	IC TC74ACT32FT
L5961	645 001 4550	INDUCTOR,10U K
or	645 031 7835	INDUCTOR,10U K
L5962	645 001 4550	INDUCTOR,10U K
or	645 031 7835	INDUCTOR,10U K
Q5301	405 000 3400	TR DTC114TS
or	405 109 9402	TR KRC111M
Q5302	405 000 3400	TR DTC114TS
or	405 109 9402	TR KRC111M
Q5303	405 143 8706	TR KTC3199-GR
or	405 017 9600	TR 2SC3330-T
or	405 017 9709	TR 2SC3330-U
or	405 011 8500	TR 2SC1740S-R
or	405 011 8609	TR 2SC1740S-S

PARTS LIST

REF.NO.	PART NO.	DESCRIPTION
Q5304	405 000 6104	TR DTC144ES
or	405 146 1209	TR KRC104M
Q5305	405 000 2205	TR DTA144ES
or	405 146 1308	TR KRA104M
Q5330	405 075 8102	TR DTA143ZS
or	405 143 8904	TR KRA106M
RA531	614 218 0525	RESISTOR
S5301	645 034 8037	SWITCH,ROTARY(ENCODER)
S5302	645 006 5958	SWITCH,PUSH 1P-1T
or	614 220 5471	SWITCH,TACT
or	614 240 1002	SWITCH,TACT
S5304	645 006 5958	SWITCH,PUSH 1P-1T
or	614 220 5471	SWITCH,TACT
or	614 240 1002	SWITCH,TACT
S5305	645 006 5958	SWITCH,PUSH 1P-1T
or	614 220 5471	SWITCH,TACT
or	614 240 1002	SWITCH,TACT
S5306	645 006 5958	SWITCH,PUSH 1P-1T
or	614 220 5471	SWITCH,TACT
or	614 240 1002	SWITCH,TACT
S5308	645 006 5958	SWITCH,PUSH 1P-1T
or	614 220 5471	SWITCH,TACT
or	614 240 1002	SWITCH,TACT
S5309	645 006 5958	SWITCH,PUSH 1P-1T
or	614 220 5471	SWITCH,TACT
or	614 240 1002	SWITCH,TACT
S5310	645 006 5958	SWITCH,PUSH 1P-1T
or	614 220 5471	SWITCH,TACT
or	614 240 1002	SWITCH,TACT
S5311	645 006 5958	SWITCH,PUSH 1P-1T
or	614 220 5471	SWITCH,TACT
or	614 240 1002	SWITCH,TACT
S5312	645 006 5958	SWITCH,PUSH 1P-1T
or	614 220 5471	SWITCH,TACT
or	614 240 1002	SWITCH,TACT
S5313	645 006 5958	SWITCH,PUSH 1P-1T
or	614 220 5471	SWITCH,TACT
or	614 240 1002	SWITCH,TACT
X5301	645 027 5470	OSC,CERAMIC 8MHZ

MD LED2 P.W.BOARD ASSY

REF.NO.	PART NO.	DESCRIPTION
73	614 303 3875	ASSY,PWB,MD LED2 (Only Initial)
CN545	614 035 4911	SOCKET,DIP 2P
or	614 237 9752	SOCKET
D5450	407 212 8907	LED HLMP-BB01-J0B00

MD LED1 P.W.BOARD ASSY

REF.NO.	PART NO.	DESCRIPTION
74	614 303 3868	ASSY,PWB,MD LED1 (Only Initial)
CN544	614 035 4911	SOCKET,DIP 2P
or	614 237 9752	SOCKET
D5440	407 212 8907	LED HLMP-BB01-J0B00

MD POWER SUPPLY P.W.BOARD ASSY

REF.NO.	PART NO.	DESCRIPTION
75	614 302 6808	ASSY,PWB,MD POWER SUPPLY (Only Initial)
C5021	403 057 0007	POLYESTER 0.01U J 50V
C5905	403 329 6003	ELECT 4700U M 25V
CN500	645 005 8134	PLUG,8P
CN501	645 006 0861	PLUG,7P
CN502	614 239 5455	SOCKET
CN503	645 035 5769	SOCKET,FPC 26P
CN572	407 212 5708	PHOTO COUPLE GP1F38R
CN573	407 212 8709	PHOTO COUPLE TOTX140
or	407 210 0408	PC PHOTO COUPLE GP1F38T
CN591	614 020 6548	SOCKET,2P
or	614 223 9209	SOCKET
CN592	614 020 6586	SOCKET,6P
D5901	△ 407 148 6701	DIODE 1A3-I
D5902	△ 407 148 6701	DIODE 1A3-I
D5903	△ 407 148 6701	DIODE 1A3-I
D5904	△ 407 148 6701	DIODE 1A3-I
D5931	△ 407 148 6701	DIODE 1A3-I
D5932	407 100 0303	ZENER DIODE MTZJ36B
D5933	407 063 9108	ZENER DIODE MTZJ6.8B
HS501	614 264 0159	HEAT SINK
IC503	409 185 6102	IC TC74HCU04AP
IC571	409 384 3506	IC BA3314F
IC572	409 426 1804	IC KIA4558S
IC573	409 333 2505	IC BU4066BCF
IC592	409 453 5400	IC NJM2930L85
IC593	409 382 0309	IC LA5620
L5701	645 001 4581	INDUCTOR,100U K
or	645 031 7842	INDUCTOR,100U K
L5801	645 001 4581	INDUCTOR,100U K
or	645 031 7842	INDUCTOR,100U K
L5901	645 001 4550	INDUCTOR,10U K
or	645 031 7835	INDUCTOR,10U K
L5902	645 001 4581	INDUCTOR,100U K
or	645 031 7842	INDUCTOR,100U K
L5903	645 006 3602	INDUCTOR,1.1UH
L5904	645 006 3602	INDUCTOR,1.1UH
L5905	645 006 3602	INDUCTOR,1.1UH
L5951	645 001 5519	INDUCTOR,47U K
LUG50	645 023 8987	FIXER,FIX_WIRE
LUG51	645 023 8987	FIXER,FIX_WIRE
PR591	△ 645 027 4169	PROTECTOR,0.125A 125V
Q5340	405 000 6104	TR DTC144ES
or	405 146 1209	TR KRC104M
Q5341	405 000 2205	TR DTA144ES
or	405 146 1308	TR KRA104M
Q5342	405 000 6104	TR DTC144ES
or	405 146 1209	TR KRC104M
Q5343	405 000 2205	TR DTA144ES
or	405 146 1308	TR KRA104M
Q5710	405 000 3400	TR DTC114TS
or	405 109 9402	TR KRC111M
Q5810	405 000 3400	TR DTC114TS
or	405 109 9402	TR KRC111M
Q5901	405 000 2205	TR DTA144ES
or	405 146 1308	TR KRA104M
Q5902	405 000 6104	TR DTC144ES
or	405 146 1209	TR KRC104M
Q5903	405 141 3505	TR KTA1266-Y
or	405 141 3406	TR KTA1266-GR
or	405 004 4502	TR 2SA608-F-NP
or	405 004 5004	TR 2SA608-G-NP
Q5904	405 143 8706	TR KTC3199-GR
or	405 017 9600	TR 2SC3330-T
or	405 017 9709	TR 2SC3330-U
or	405 011 8500	TR 2SC1740S-R
or	405 011 8609	TR 2SC1740S-S

PARTS LIST

REF.NO.	PART NO.	DESCRIPTION
Q5905	405 007 3106	TR 2SB544-F-MP
or	405 007 2901	TR 2SB544-E-MP
Q5931	405 141 3505	TR KTA1266-Y
or	405 141 3406	TR KTA1266-GR
or	405 004 4502	TR 2SA608-F-NP
or	405 004 5004	TR 2SA608-G-NP
SA001	411 021 3503	SCR S-TPG BIN 3X10, FOR IC593

MD PT-PRE P.W.BOARD ASSY

REF.NO.	PART NO.	DESCRIPTION
76	614 303 3882	ASSY,PWB,MD PT-PRE (Only Initial)
CN596	614 020 6548	SOCKET,2P
or	614 223 9209	SOCKET
L5960	614 213 5761	INDUCTOR, FERITE

MD PT-SEC P.W.BOARD ASSY

REF.NO.	PART NO.	DESCRIPTION
77	614 302 6815	ASSY,PWB,MD PT-SEC (Only Initial)
CN599	614 020 6586	SOCKET,6P
PR599	△ 645 014 2550	PROTECTOR,2A 125V

MD MECHANISM (MDG007/SH)

REF.NO.	PART NO.	DESCRIPTION
MM00	614 304 8350	ASSY,MECHA,MDG007/SH,MD MECHA
MM01	614 303 8344	ASSY,DOOR,MD DOOR W/PAINTING
MM02	614 303 6609	SHAFT,DOOR,MD DOOR SHAFT
MM03	614 303 6616	SPRING,DOOR,MD DOOR RETURN

FL DISPLAY & DESCRIPTION

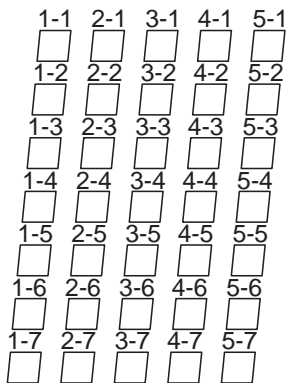
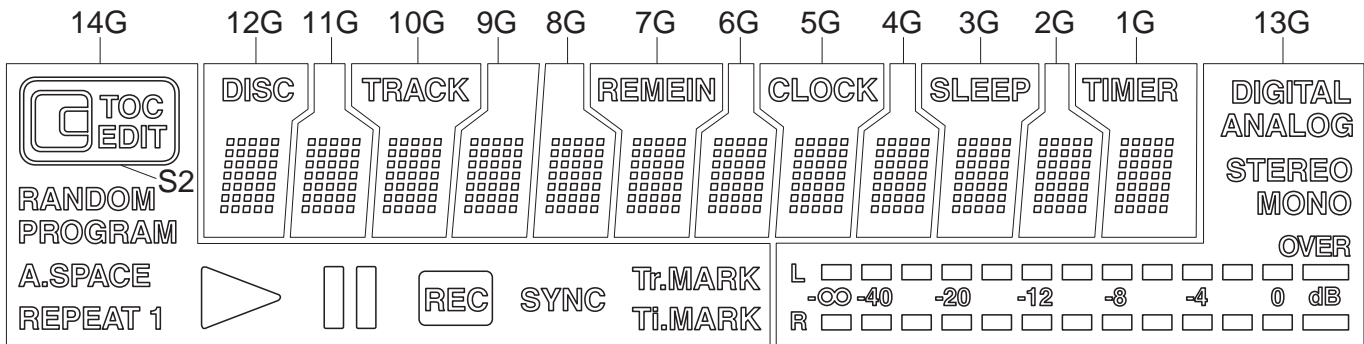

(12G~1G)

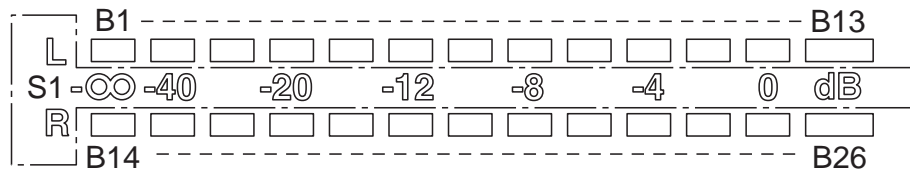

(13G)

PIN CONNECTION

PIN NO.	60	59	58	57	56	55	54	53	52	51	50	49	48	47	46	45	44	43	42	41
CONNECTION	F2	F2	NP	NP	14G	13G	12G	11G	10G	9G	8G	7G	6G	5G	4G	3G	2G	1G	NC	NC

PIN NO.	40	39	38	37	36	35	34	33	32	31	30	29	28	27	26	25	24	23	22	21
CONNECTION	P1	P2	P3	P4	P5	P6	P7	P8	P9	P10	P11	P12	P13	P14	P15	P16	P17	P18	P19	P20

PIN NO.	20	19	18	17	16	15	14	13	12	11	10	9	8	7	6	5	4	3	2	1
CONNECTION	P21	P22	P23	P24	P25	P26	P27	P28	P29	P30	P31	P32	P33	P34	P35	P36	NP	NP	F1	F1

- NOTE: 1) F1,F2 Filament
 2) NP No pin
 3) NC No connection
 4) DL Datum Line
 5) 1G ~ 14G Grid

FL DISPLAY & DESCRIPTION

ANODE CONNECTION		14G	13G	12G	11G	10G	9G	8G	7G	6G	5G	4G	3G	2G	1G
P1		---	MONO	DISC	---	TRACK	---	---	REMAIN	---	CLOCK	---	SLEEP	---	---
P2				1-1	1-1	1-1	1-1	1-1	1-1	1-1	1-1	1-1	1-1	1-1	1-1
P3	TOC	B1	2-1	2-1	2-1	2-1	2-1	2-1	2-1	2-1	2-1	2-1	2-1	2-1	2-1
P4	EDIT	B8	3-1	3-1	3-1	3-1	3-1	3-1	3-1	3-1	3-1	3-1	3-1	3-1	3-1
P5	S2	B14	4-1	4-1	4-1	4-1	4-1	4-1	4-1	4-1	4-1	4-1	4-1	4-1	4-1
P6	RANDOM	B21	5-1	5-1	5-1	5-1	5-1	5-1	5-1	5-1	5-1	5-1	5-1	5-1	5-1
P7	RPROGRAM	---	1-2	1-2	1-2	1-2	1-2	1-2	1-2	1-2	1-2	1-2	1-2	1-2	1-2
P8	A.SPACE	B21	2-2	2-2	2-2	2-2	2-2	2-2	2-2	2-2	2-2	2-2	2-2	2-2	2-2
P9	REPEAT	B9	3-2	3-2	3-2	3-2	3-2	3-2	3-2	3-2	3-2	3-2	3-2	3-2	3-2
P10	1	B15	4-2	4-2	4-2	4-2	4-2	4-2	4-2	4-2	4-2	4-2	4-2	4-2	4-2
P11	▷	B22	5-2	5-2	5-2	5-2	5-2	5-2	5-2	5-2	5-2	5-2	5-2	5-2	5-2
P12	⏮	---	1-3	1-3	1-3	1-3	1-3	1-3	1-3	1-3	1-3	1-3	1-3	1-3	1-3
P13	REC	B3	2-3	2-3	2-3	2-3	2-3	2-3	2-3	2-3	2-3	2-3	2-3	2-3	2-3
P14	SYNC	B10	3-3	3-3	3-3	3-3	3-3	3-3	3-3	3-3	3-3	3-3	3-3	3-3	3-3
P15	TtMARK	B16	4-3	4-3	4-3	4-3	4-3	4-3	4-3	4-3	4-3	4-3	4-3	4-3	4-3
P16	TIMARK	B23	5-3	5-3	5-3	5-3	5-3	5-3	5-3	5-3	5-3	5-3	5-3	5-3	5-3
P17	---	---	1-4	1-4	1-4	1-4	1-4	1-4	1-4	1-4	1-4	1-4	1-4	1-4	1-4
P18	---	B4	2-4	2-4	2-4	2-4	2-4	2-4	2-4	2-4	2-4	2-4	2-4	2-4	2-4
P19	---	B11	3-4	3-4	3-4	3-4	3-4	3-4	3-4	3-4	3-4	3-4	3-4	3-4	3-4
P20	---	B17	4-4	4-4	4-4	4-4	4-4	4-4	4-4	4-4	4-4	4-4	4-4	4-4	4-4
P21	---	B24	5-4	5-4	5-4	5-4	5-4	5-4	5-4	5-4	5-4	5-4	5-4	5-4	5-4
P22	---	S1	1-5	1-5	1-5	1-5	1-5	1-5	1-5	1-5	1-5	1-5	1-5	1-5	1-5
P23	---	B5	2-5	2-5	2-5	2-5	2-5	2-5	2-5	2-5	2-5	2-5	2-5	2-5	2-5
P24	---	B12	3-5	3-5	3-5	3-5	3-5	3-5	3-5	3-5	3-5	3-5	3-5	3-5	3-5
P25	---	B18	4-5	4-5	4-5	4-5	4-5	4-5	4-5	4-5	4-5	4-5	4-5	4-5	4-5
P26	---	B25	5-5	5-5	5-5	5-5	5-5	5-5	5-5	5-5	5-5	5-5	5-5	5-5	5-5
P27	---	OVER	1-6	1-6	1-6	1-6	1-6	1-6	1-6	1-6	1-6	1-6	1-6	1-6	1-6
P28	---	B6	2-6	2-6	2-6	2-6	2-6	2-6	2-6	2-6	2-6	2-6	2-6	2-6	2-6
P29	---	B13	3-6	3-6	3-6	3-6	3-6	3-6	3-6	3-6	3-6	3-6	3-6	3-6	3-6
P30	---	B19	4-6	4-6	4-6	4-6	4-6	4-6	4-6	4-6	4-6	4-6	4-6	4-6	4-6
P31	---	B26	5-6	5-6	5-6	5-6	5-6	5-6	5-6	5-6	5-6	5-6	5-6	5-6	5-6
P32	---	DIGITAL	1-7	1-7	1-7	1-7	1-7	1-7	1-7	1-7	1-7	1-7	1-7	1-7	1-7
P33	---	B7	2-7	2-7	2-7	2-7	2-7	2-7	2-7	2-7	2-7	2-7	2-7	2-7	2-7
P34	---	ANALOG	3-7	3-7	3-7	3-7	3-7	3-7	3-7	3-7	3-7	3-7	3-7	3-7	3-7
P35	---	B20	4-7	4-7	4-7	4-7	4-7	4-7	4-7	4-7	4-7	4-7	4-7	4-7	4-7
P36	---	STEREO	5-7	5-7	5-7	5-7	5-7	5-7	5-7	5-7	5-7	5-7	5-7	5-7	5-7

IC BLOCK DIAGRAM & DESCRIPTION

IC503 TC74HCU04AP (HEX INVERTER)

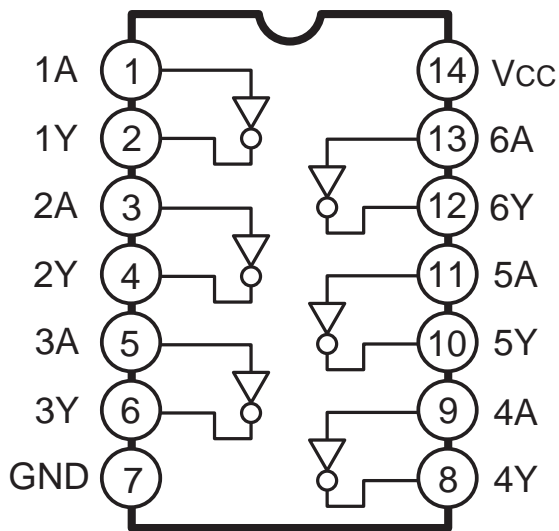

IC532 TC74ACT32FT (Serial EEPROM)

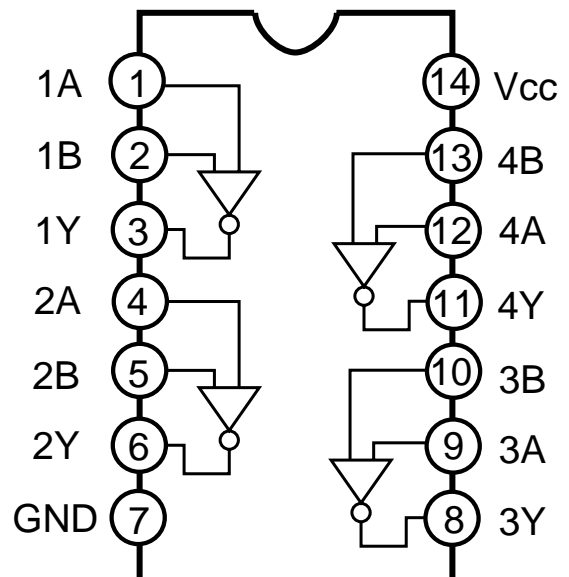

IC BLOCK DIAGRAM & DESCRIPTION

IC571 BA3314F (Dula Preamplifier with ALC Detector)

IC572 KIA4558S (Dula Low Noise Operational Amp.)

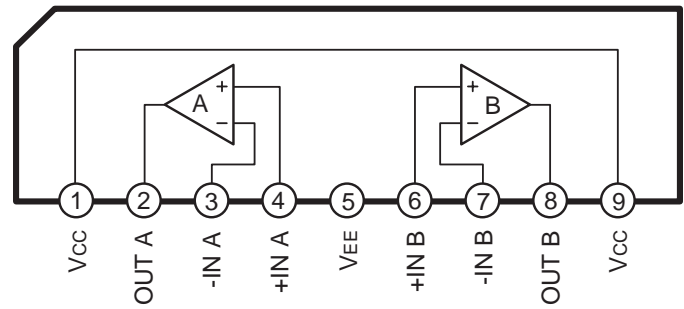
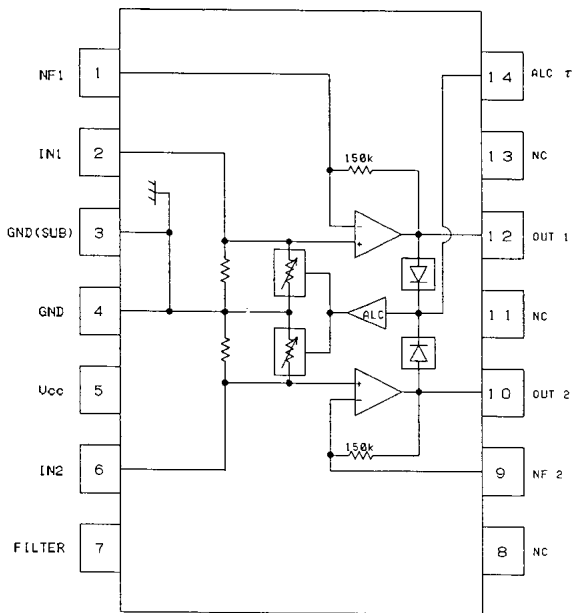

IC573 BU4066BCF (Quad Analog Switch)

IC593 LA5620 (Multi Voltage System Regulator)

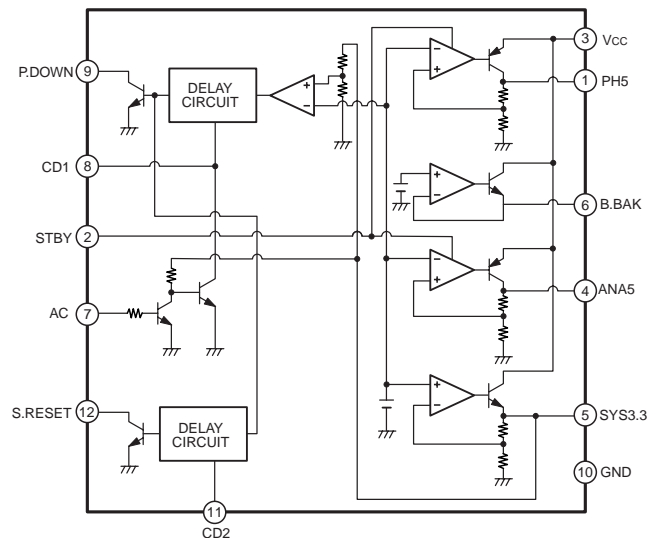
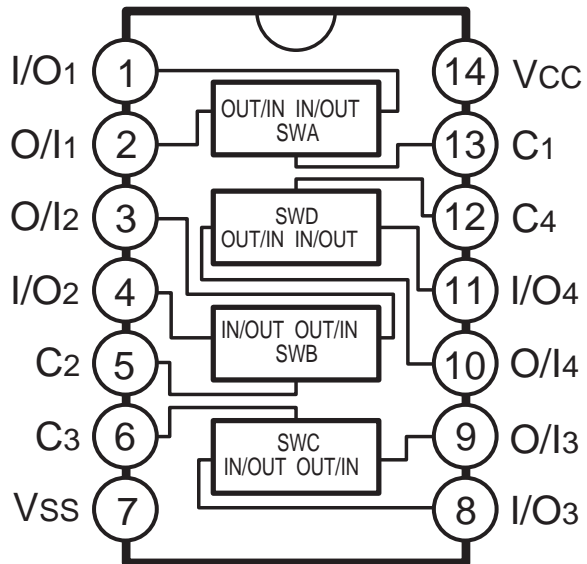

SCHEMATIC DIAGRAM (FRONT)

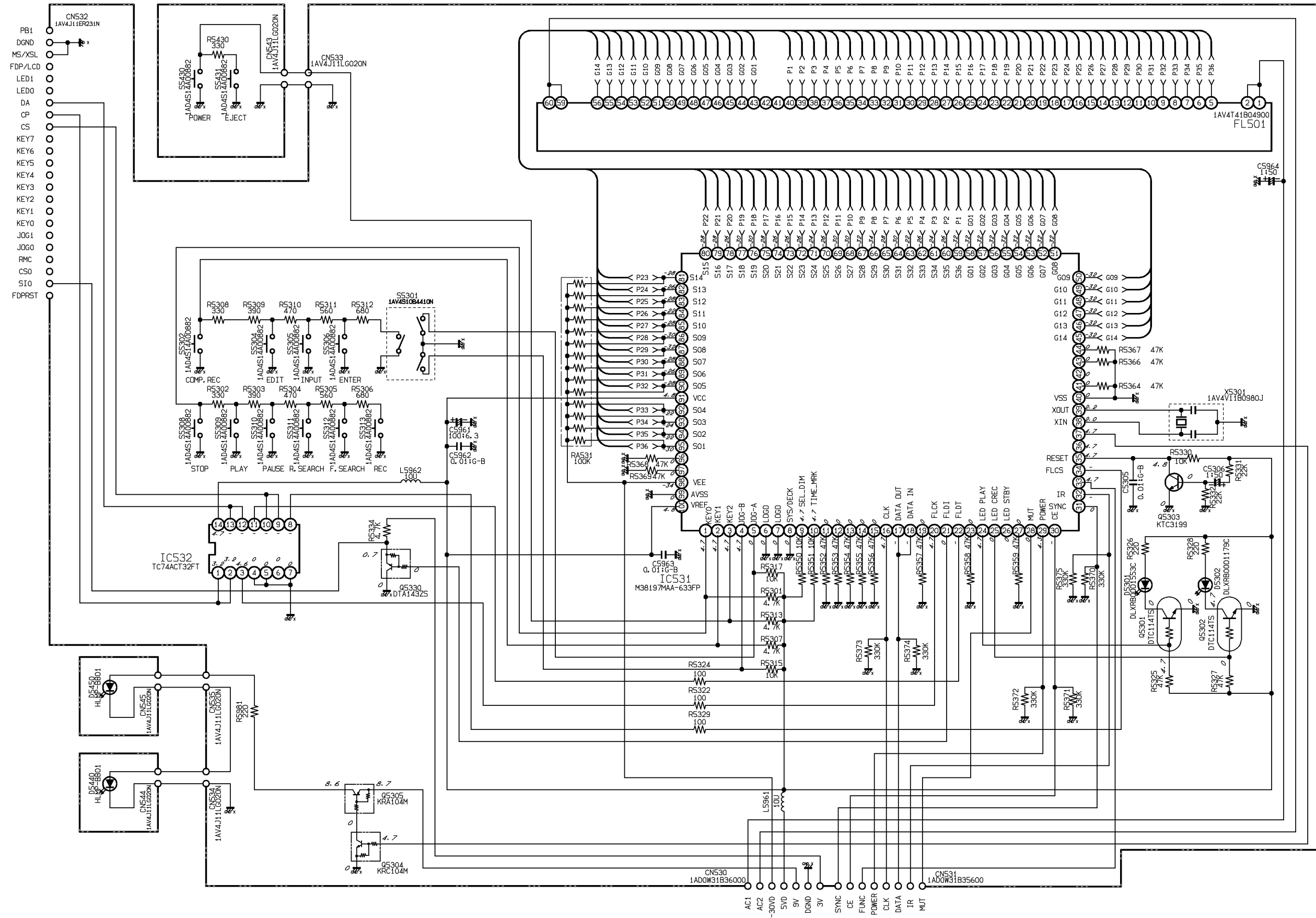

This is a basic schematic diagram.

SCHEMATIC DIAGRAM (MAIN)

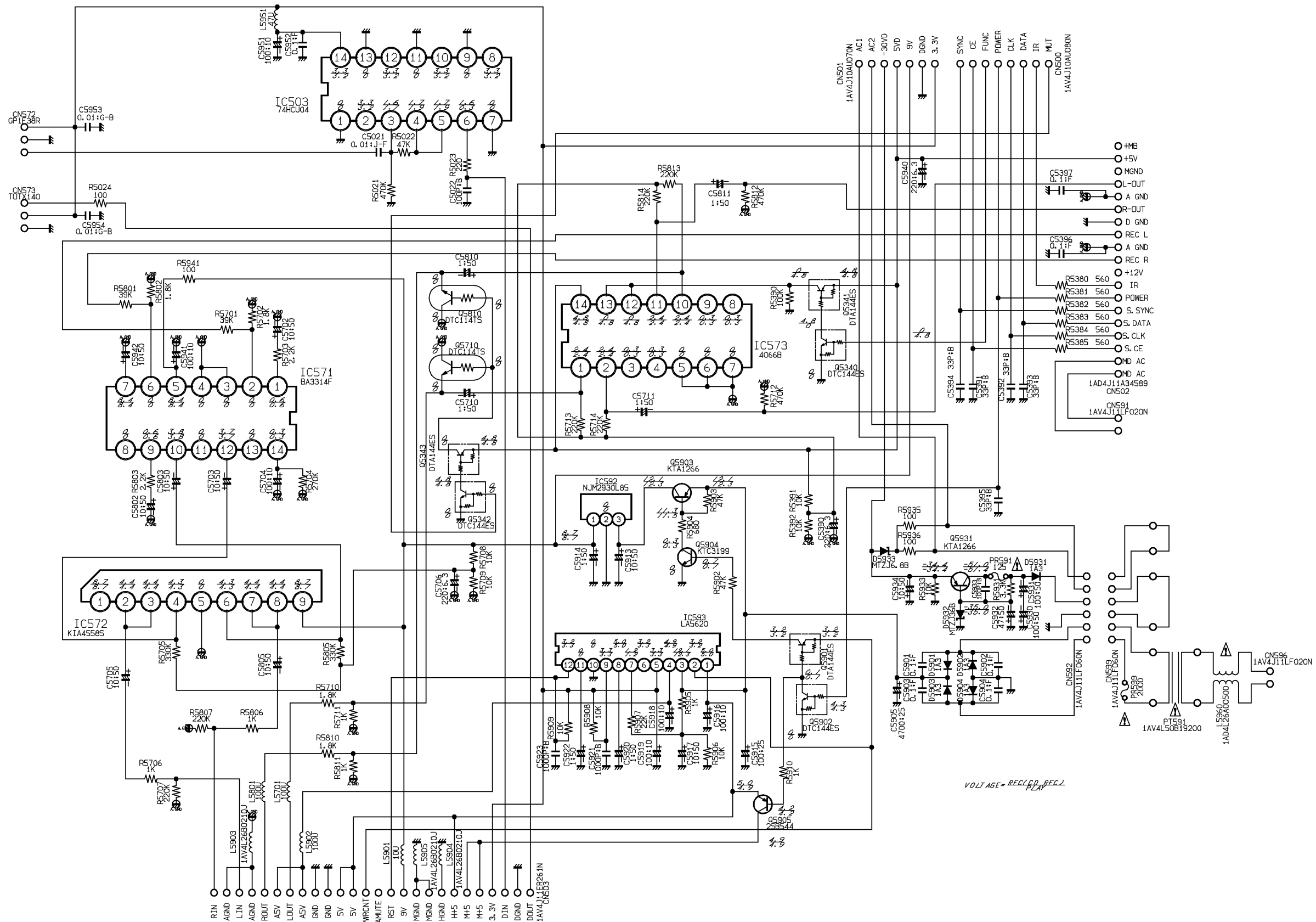

This is a basic schematic diagram.

PRODUCT SAFETY NOTICE

Each precaution in this manual should be followed during servicing. Components identified with the IEC symbol Δ in the parts list and the schematic diagram designated components in which safety can be of special significance. When replacing a component identified by Δ , use only the replacement parts designated, or parts with the same ratings of resistance, wattage or voltage that are designated in the parts list in this manual. Leakage-current or resistance measurements must be made to determine that exposed parts are acceptably insulated from the supply circuit before returning the product to the customer.

WIRING DIAGRAM

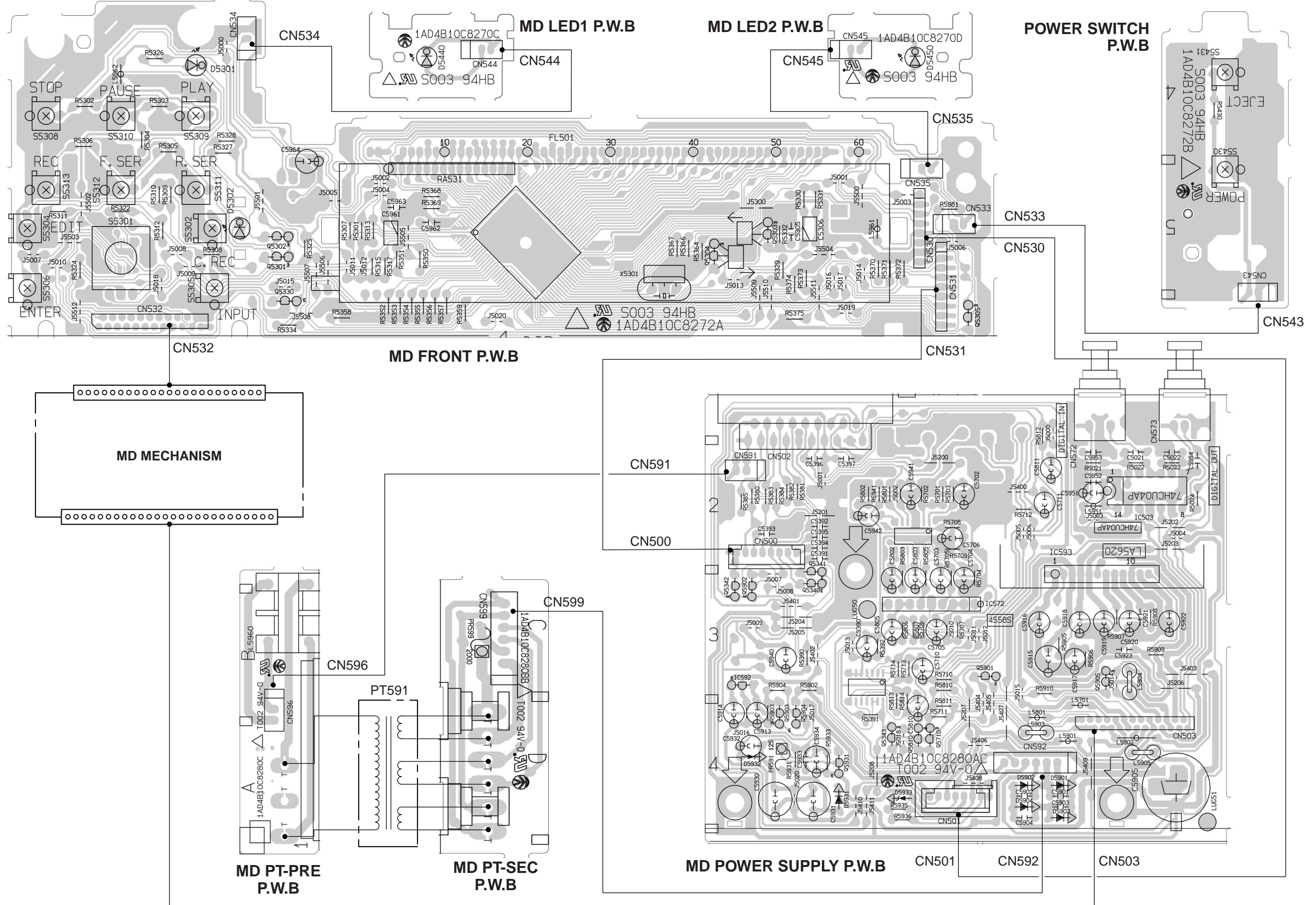

IC BLOCK DIAGRAM & DESCRIPTION

IC531 M38197MAA-636FP (Single Chip 8-bit C Mos)

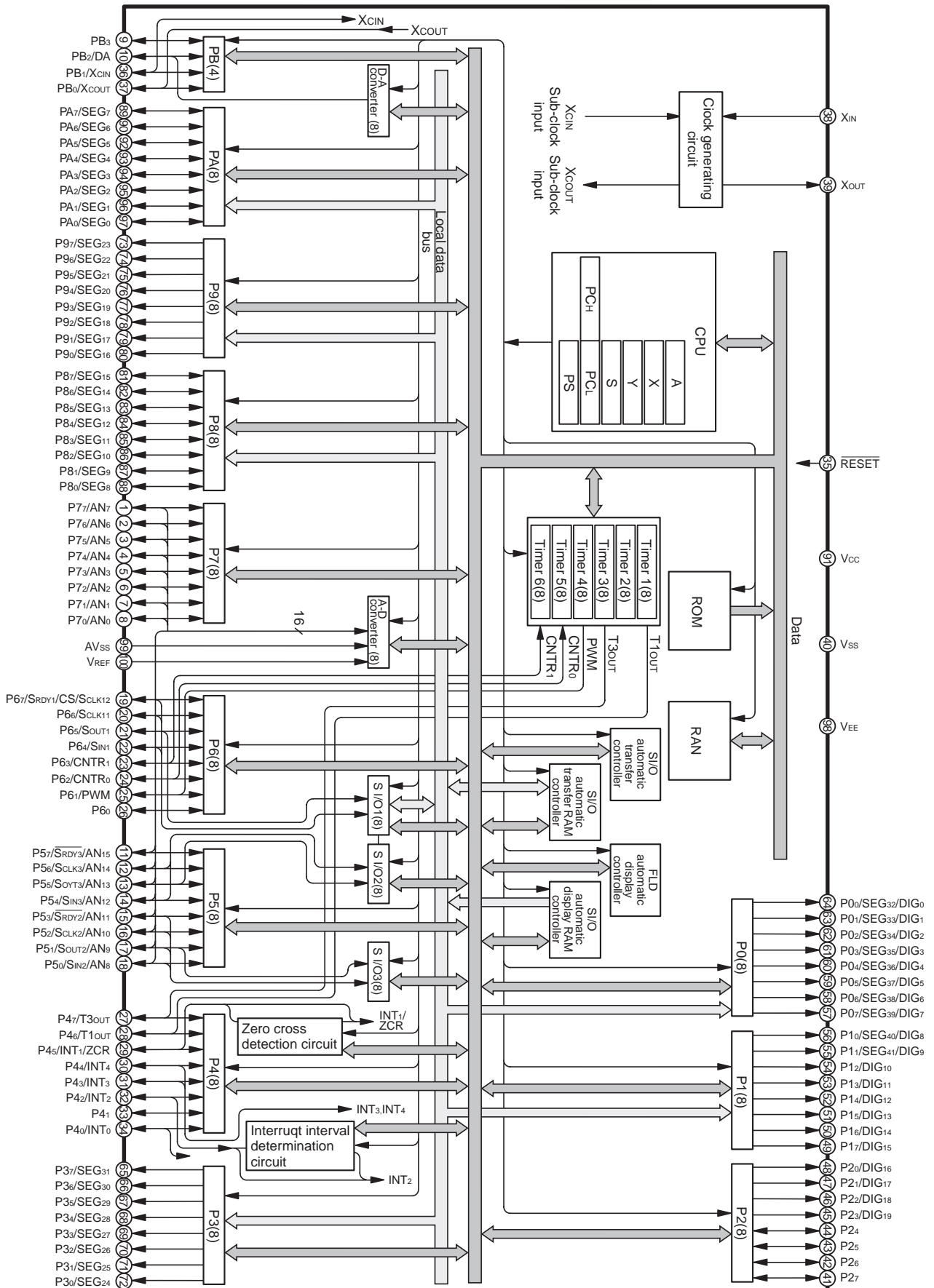

IC BLOCK DIAGRAM & DESCRIPTION

Pin	Name	Function
1	P7 ₇ /AN ₇	
2	P7 ₆ /AN ₆	
3	P7 ₅ /AN ₅	8-bit C MOS I/O port with the same function as ports P2 - P2 ₇
4	P7 ₄ /AN ₄	
5	P7 ₃ /AN ₃	C MOS compatible input level
6	P7 ₂ /AN ₂	C MOS 3-state output
7	P7 ₁ /AN ₁	
8	P7 ₀ /AN ₀	
9	PB ₃	4-bit C MOS I/O port with the same function as ports P2 ₄ - P2 ₇
10	PB ₂ /DA	C MOS compatible input level C MOS 3-state output
11	P5 ₇ /S _{RDY3} /AN ₁₅	
12	P5 ₆ /S _{CLK3} /AN ₁₄	
13	P5 ₅ /S _{OUT3} /AN ₁₃	
14	P5 ₄ /S _{IN3} /AN ₁₂	
15	P5 ₃ /S _{RDY2} /AN ₁₁	8-bit C MOS I/O port with the same function as ports P2 ₄ - P2 ₇
16	P5 ₂ /S _{CLK2} /AN ₁₀	
17	P5 ₁ /S _{OUT2} /AN ₉	C MOS compatible input level
18	P5 ₀ /S _{IN2} /AN ₈	C MOS 3-state output
19	P6 ₇ /S _{RDY1} /CS/S _{CLK12}	
20	P6 ₆ /S _{CLK11}	
21	P6 ₅ /S _{OUT1}	
22	P6 ₄ /S _{IN1}	
23	P6 ₃ /CNTR ₁	
24	P6 ₂ /CNTR ₀	
25	P6 ₁ /PWM	
26	P6 ₀	
27	P4 ₇ /T3 _{OUT}	6-bit C MOS I/O port with the same function as ports P2 ₄ - P2 ₇
28	P4 ₆ /T1 _{OUT}	C MOS compatible input level C MOS 3-state output
29	P4 ₅ /INT ₁ /ZCR	2-bit input port C MOS compatible input level
30	P4 ₄ /INT ₄	6-bit C MOS I/O port with the same function as ports P2 ₄ - P2 ₇
31	P4 ₃ /INT ₃	
32	P4 ₂ /INT ₂	C MOS compatible input level
33	P4 ₁	C MOS 3-state output
34	P4 ₀ /INT ₀	2-bit input port C MOS compatible input level
35	RESET	Reset input pin for active "L"
36	PB ₁ /X _{CIN}	4-bit C MOS I/O port with the same function as ports P2 ₄ - P2 ₇
37	PB ₀ /X _{OUT}	C MOS compatible input level C MOS 3-state output
38	X _{IN}	Input and output pins for the main clock generating circuit. Feedback resistor is built in between X _{IN} pin and X _{OUT} pin. Connect a ceramic resonator or a quartz-crystal oscillator between the X _{IN} pin and X _{OUT} pin to set oscillation frequency.
39	X _{OUT}	If an external clock is used, connect the clock source to the X _{IN} pin and leave the X _{OUT} pin open. This clock is used as the oscillating source of system clock.
40	V _{SS}	Apply voltage of 0V to V _{SS}
41	P2 ₇	4-bit I/O port
42	P2 ₆	I/O direction register allows each pin to individually programmed as either input or output.
43	P2 ₅	At reset this port is set to input mode.
44	P2 ₄	TTL input level C MOS 3-state output

Pin	Name	Function
45	P2 ₃ /DIG ₁₉	
46	P2 ₂ /DIG ₁₈	4-bit output port with the same function as port P0
47	P2 ₁ /DIG ₁₇	
48	P2 ₀ /DIG ₁₆	
49	P1 ₇ /DIG ₁₅	
50	P1 ₆ /DIG ₁₄	
51	P1 ₅ /DIG ₁₃	
52	P1 ₄ /DIG ₁₂	8-bit output port with the same function as port P0
53	P1 ₃ /DIG ₁₁	
54	P1 ₂ /DIG ₁₀	
55	P1 ₁ /SEG ₄₁ /DIG ₉	
56	P1 ₀ /SEG ₄₀ /DIG ₈	
57	P0 ₇ /SEG ₃₉ /DIG ₇	
58	P0 ₆ /SEG ₃₈ /DIG ₆	8-bit output port
59	P0 ₅ /SEG ₃₇ /DIG ₅	This port builds in pull-down resistor between port P0 and the V _{EE} pin
60	P0 ₄ /SEG ₃₆ /DIG ₄	At reset this port is set to V _{EE} level
61	P0 ₃ /SEG ₃₅ /DIG ₃	The high-breakdown-voltage P-channel open-drain
62	P0 ₂ /SEG ₃₄ /DIG ₂	
63	P0 ₁ /SEG ₃₃ /DIG ₁	
64	P0 ₀ /SEG ₃₂ /DIG ₀	
65	P3 ₇ /SEG ₃₁	
66	P3 ₆ /SEG ₃₀	
67	P3 ₅ /SEG ₂₉	
68	P3 ₄ /SEG ₂₈	8-bit output port with the same function as port P0
69	P3 ₃ /SEG ₂₇	
70	P3 ₂ /SEG ₂₆	
71	P3 ₁ /SEG ₂₅	
72	P3 ₀ /SEG ₂₄	
73	P9 ₇ /SEG ₂₃	
74	P9 ₆ /SEG ₂₂	
75	P9 ₅ /SEG ₂₁	
76	P9 ₄ /SEG ₂₀	8-bit output port with the same function as port P0
77	P9 ₃ /SEG ₁₉	
78	P9 ₂ /SEG ₁₈	
79	P9 ₁ /SEG ₁₇	
80	P9 ₀ /SEG ₁₆	
81	P8 ₇ /SEG ₁₅	
82	P8 ₆ /SEG ₁₄	
83	P8 ₅ /SEG ₁₃	8-bit I/O port with the same function as ports P2 ₄ -P2 ₇
84	P8 ₄ /SEG ₁₂	
85	P8 ₃ /SEG ₁₁	C MOS compatible input level
86	P8 ₂ /SEG ₁₀	The high-breakdown-voltage P-channel open-drain
87	P8 ₁ /SEG ₉	
88	P8 ₀ /SEG ₈	
89	PA ₇ /SEG ₇	
90	PA ₆ /SEG ₆	
91	V _{CC}	Apply voltage of 4.0 to 5.5V to V _{CC}
92	PA ₅ /SEG ₅	8-bit I/O port with the same function as ports P2 ₄ -P2 ₇
93	PA ₄ /SEG ₄	
94	PA ₃ /SEG ₃	C MOS compatible input level
95	PA ₂ /SEG ₂	The high-breakdown-voltage P-channel open-drain
96	PA ₁ /SEG ₁	
97	PA ₀ /SEG ₀	
98	V _{EE}	Applies voltage supplied to pull-down resistors of ports P0, P1, P2 ₀ -P2 ₃ , P3 and P9
99	AV _{SS}	GND input pin for A-D converter and D-A converter Connect AV _{SS} to V _{SS}
100	V _{REF}	Reference voltage input pin for A-D converter and D-A converter



SANYO Technosound Co., Ltd.
Osaka, Japan